

# DIY MEDICAL VISOR

TEMPLATE INSTRUCTIONS ON HOW TO MAKE YOUR OWN FORMING MACHINE TO MAKE MUCH NEEDED MEDICAL VISORS IN MINUTES!

The video to accompany this tutorial can be found here  
<https://www.1sttrackdents.co.uk/coronavirus>

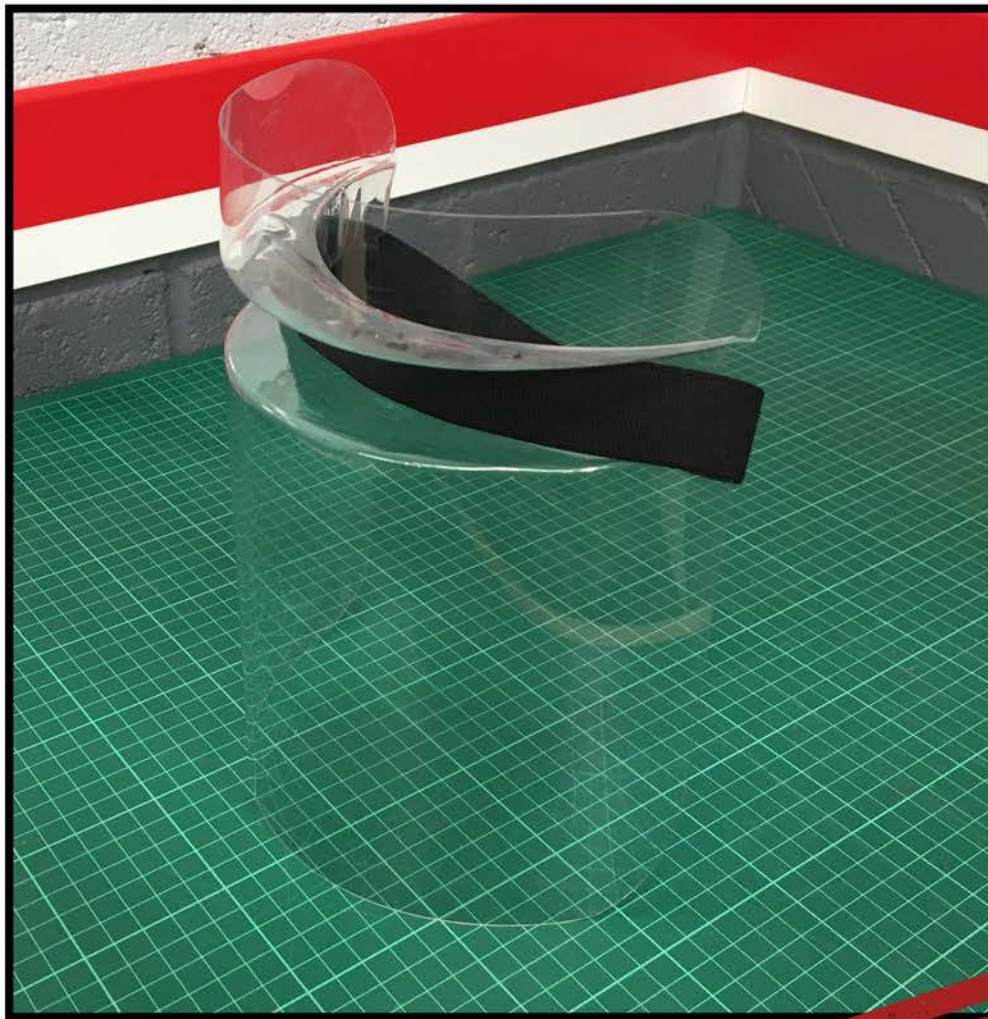

**NO 3D PRINTER  
REQUIRED!**

## DISCLAIMER

By downloading this PDF document and following the instructions inside and from watching the instructions from the relevant video that accompanies these instructions, you take full responsibility for making all the parts needed to make this product. This project is not meant for children and should only be attempted by a competent adult. Anything in this document is undertaken at your own risk.

# TOOLS & MATERIALS NEEDED

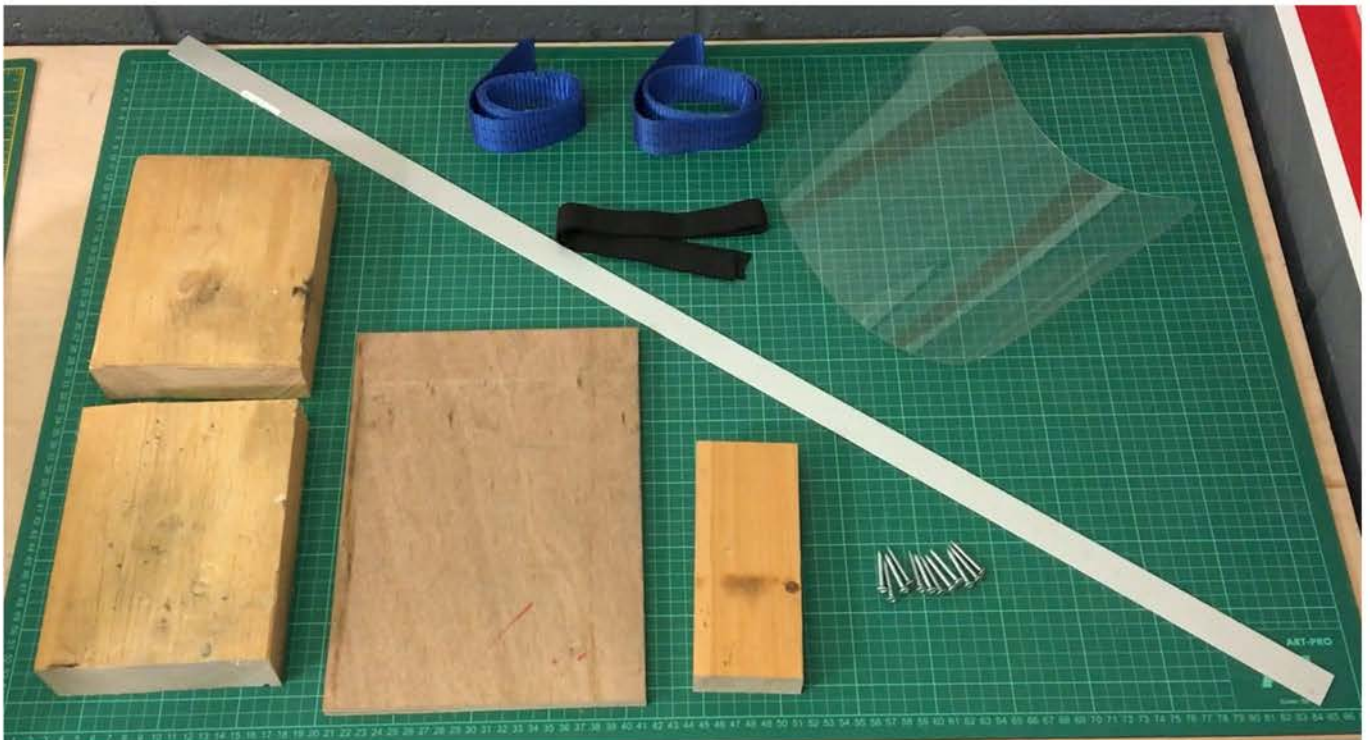

# MAIN PARTS

## FORMING MACHINE - COMPLETE

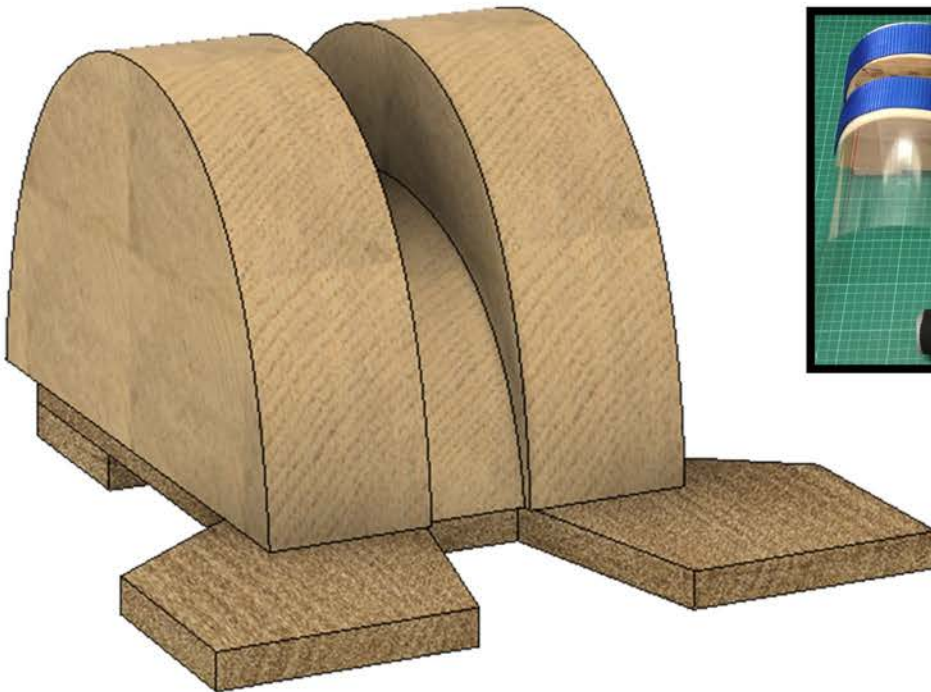

## FORMING MACHINE - EXPLODED PARTS LIST

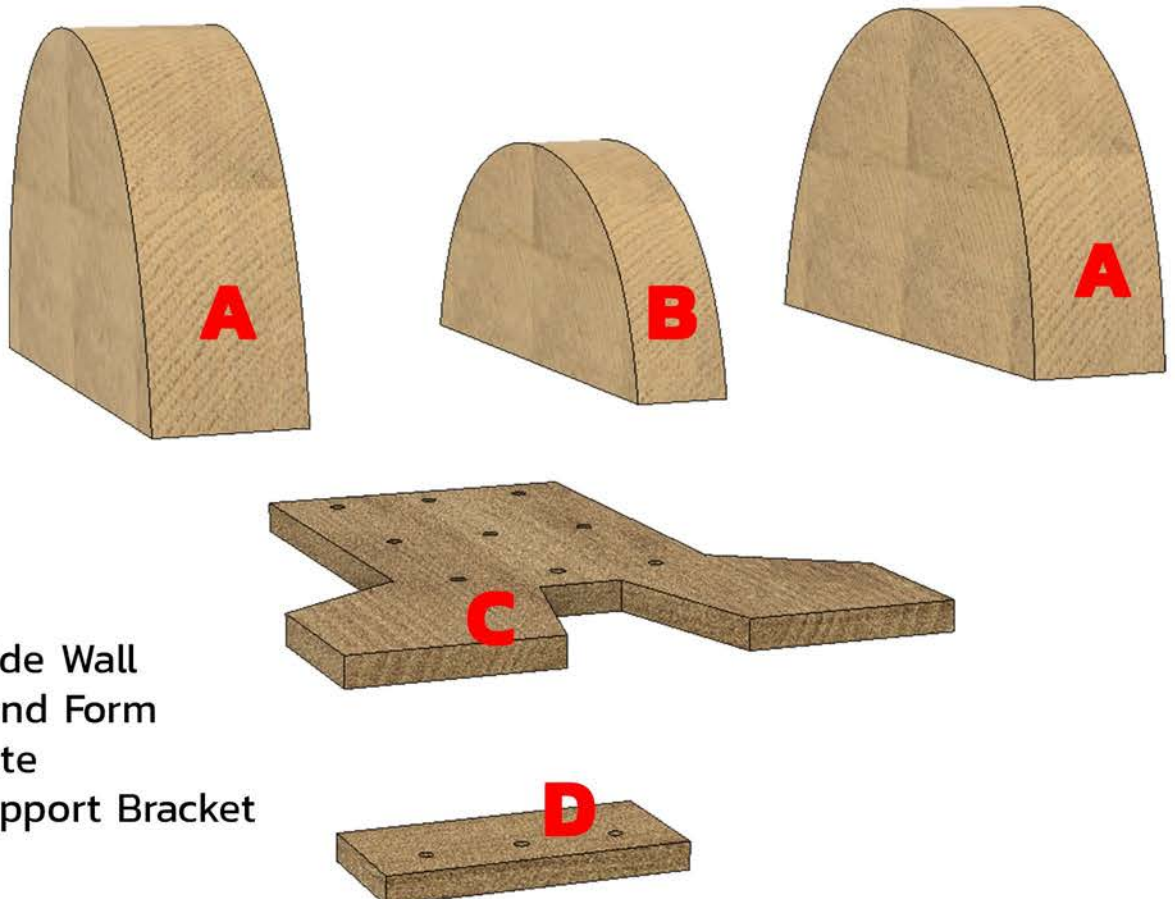

- A= Outer Side Wall
- B= Head Band Form
- C= Base Plate
- D= Strap Support Bracket

**The following pages need to be printed and then cut out using a pair of scissors**

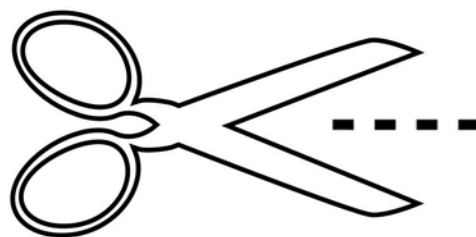
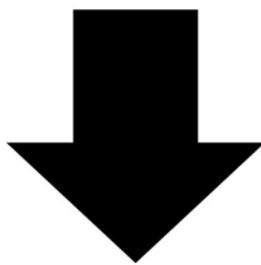
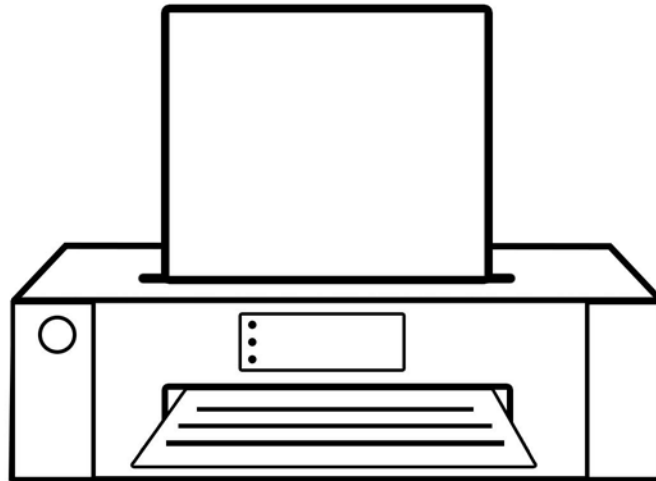

**CHECK THE PRINT-OUT HAS THE SAME DIMENSIONS, OTHERWISE ADJUST THE SCALE ON YOUR PRINTER**

# A

## OUTER SIDE WALL

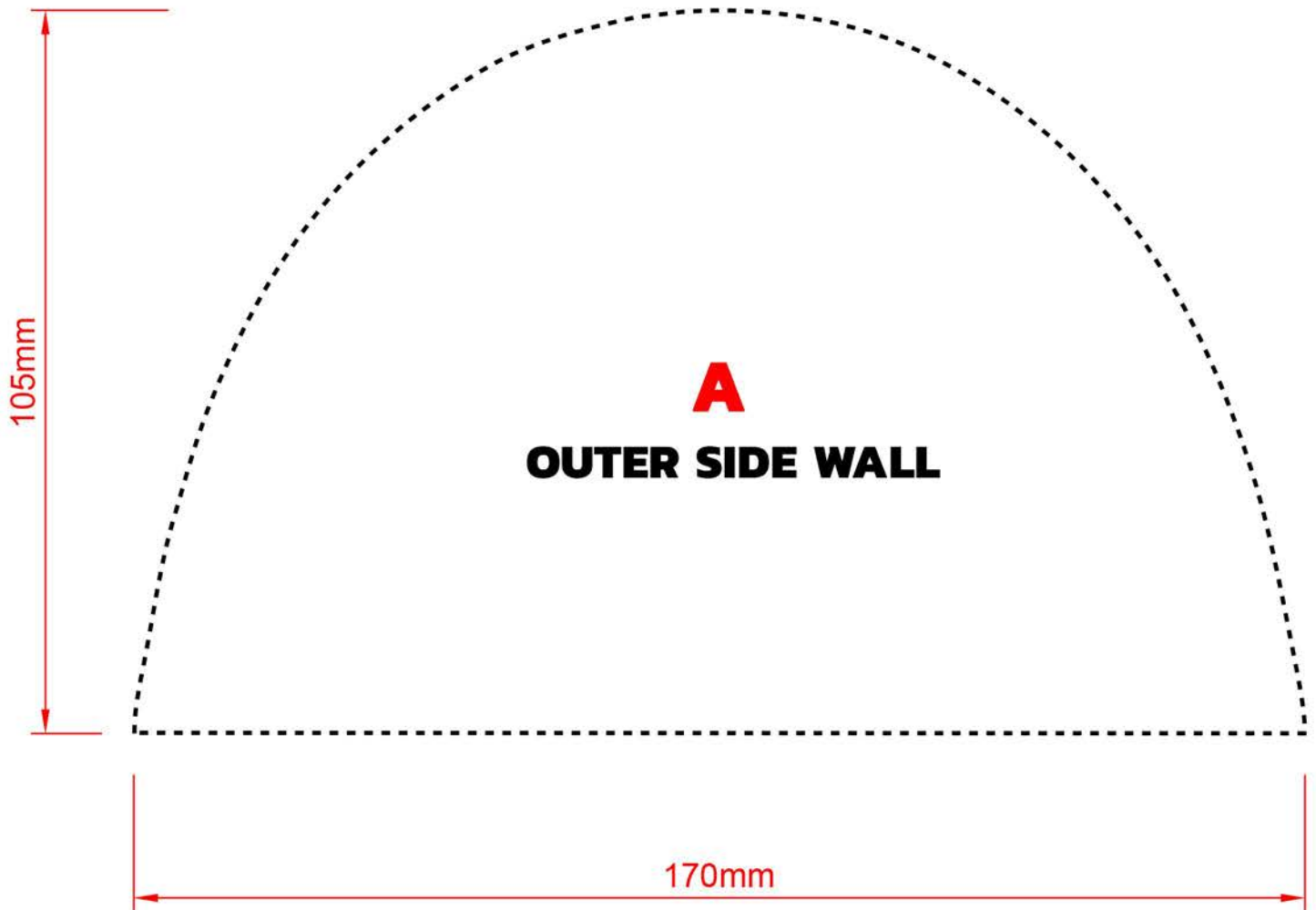
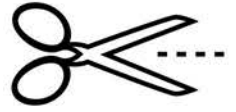

**(THICKNESS OF THIS PART NEEDS TO BE 45mm OR MORE)**

# B

# HEADBAND FORM

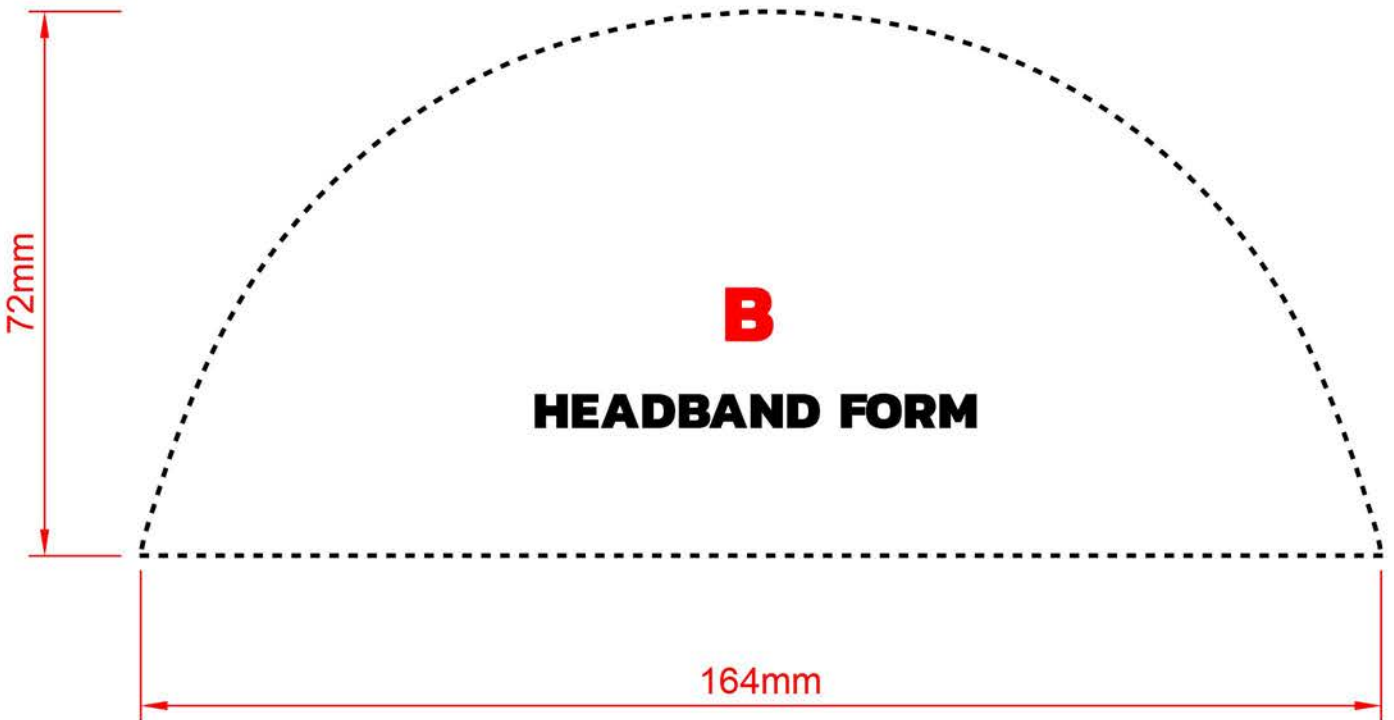
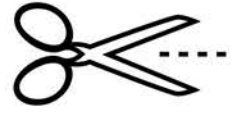

**(THICKNESS OF THIS PART NEEDS TO BE 28mm)**

# C

## BASE PLATE

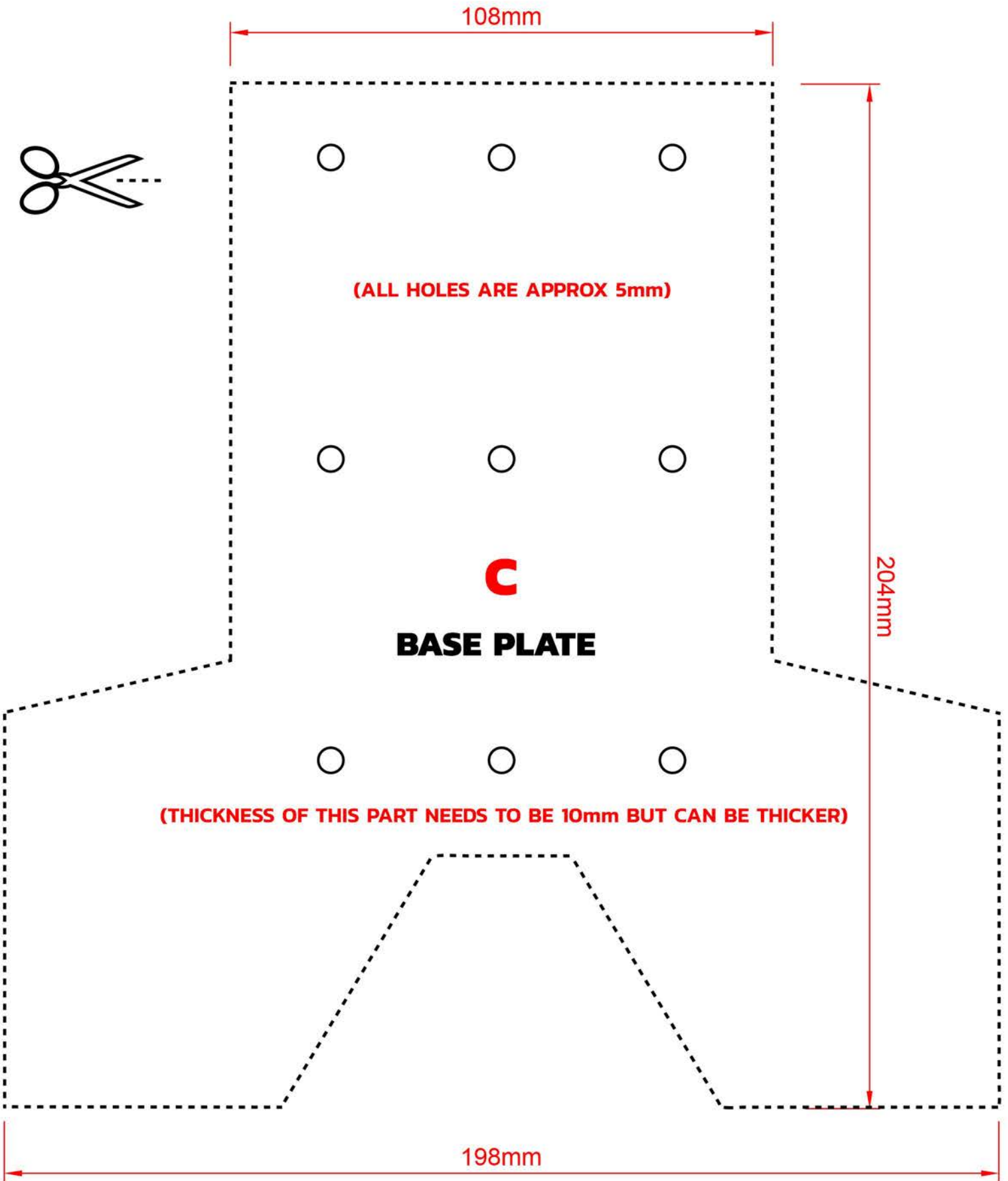

# D

# STRAP SUPPORT BRACKET

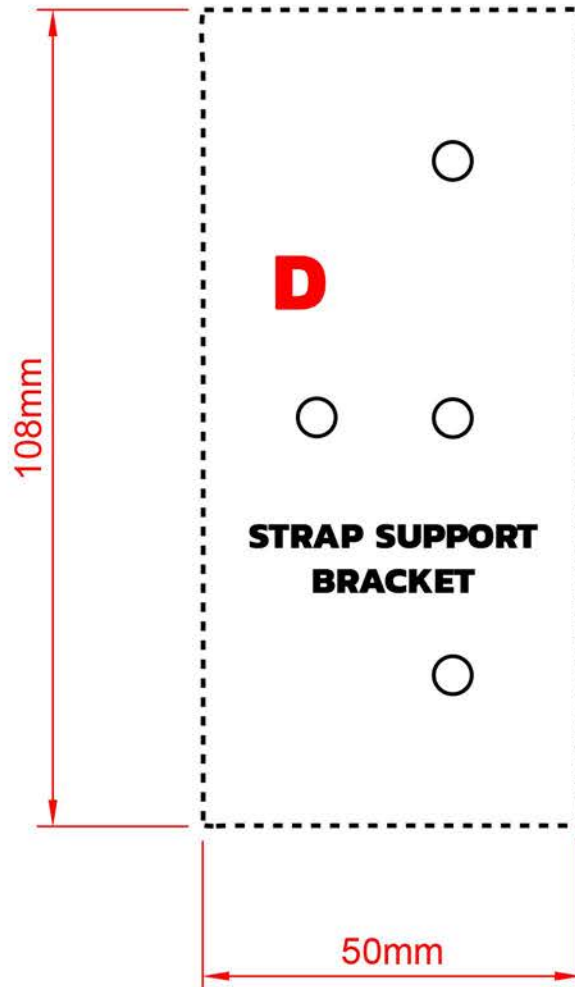
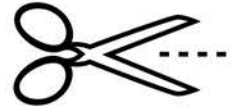

(ALL HOLES ARE APPROX 5mm)

(THICKNESS OF THIS PART NEEDS TO BE 10mm, BUT CAN BE THICKER)



# E

# PLASTIC VISOR SHAPE

144mm



**E**

**LEFT SIDE**

(Total length is 233mm x 288mm with LEFT & RIGHT sides together)

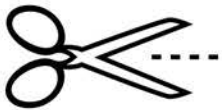

**PLASTIC VISOR SHAPE**

**MATERIAL USED FOR THIS CLEAR VISOR  
IS 0.5MM PETG**

233mm

**E**

# PLASTIC VISOR SHAPE

144mm

233mm



**E**

**RIGHT SIDE**

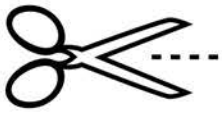

**PLASTIC VISOR SHAPE**

**MATERIAL USED FOR THIS CLEAR VISOR  
IS 0.5MM PETG**

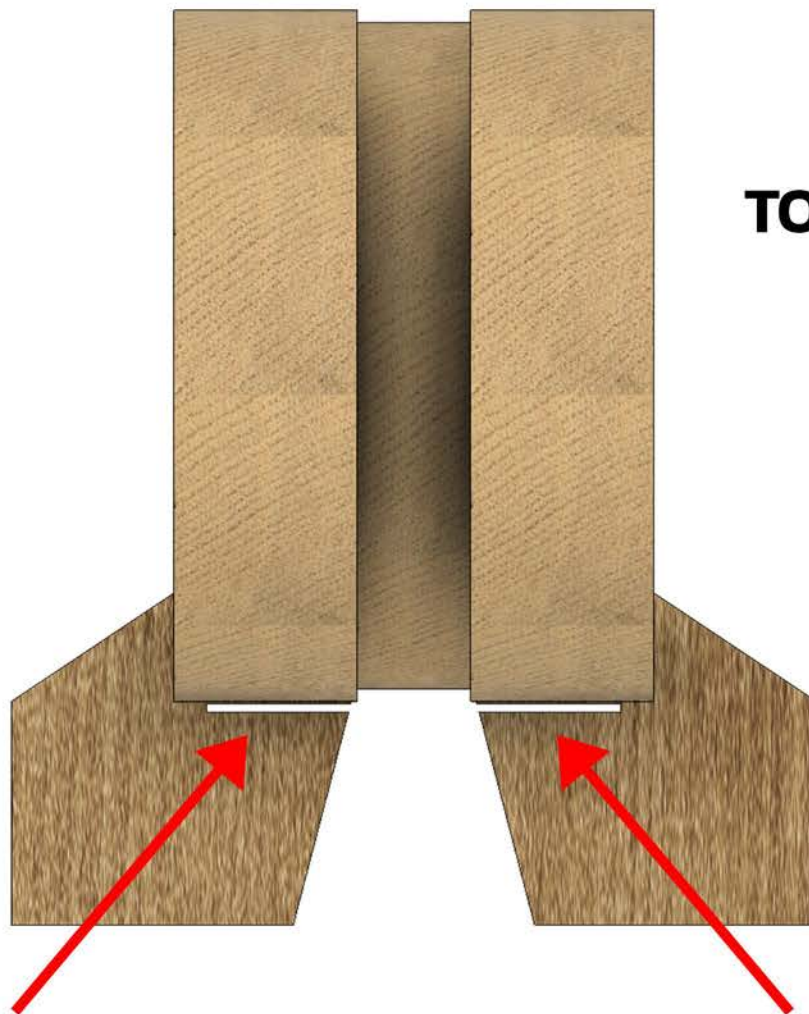
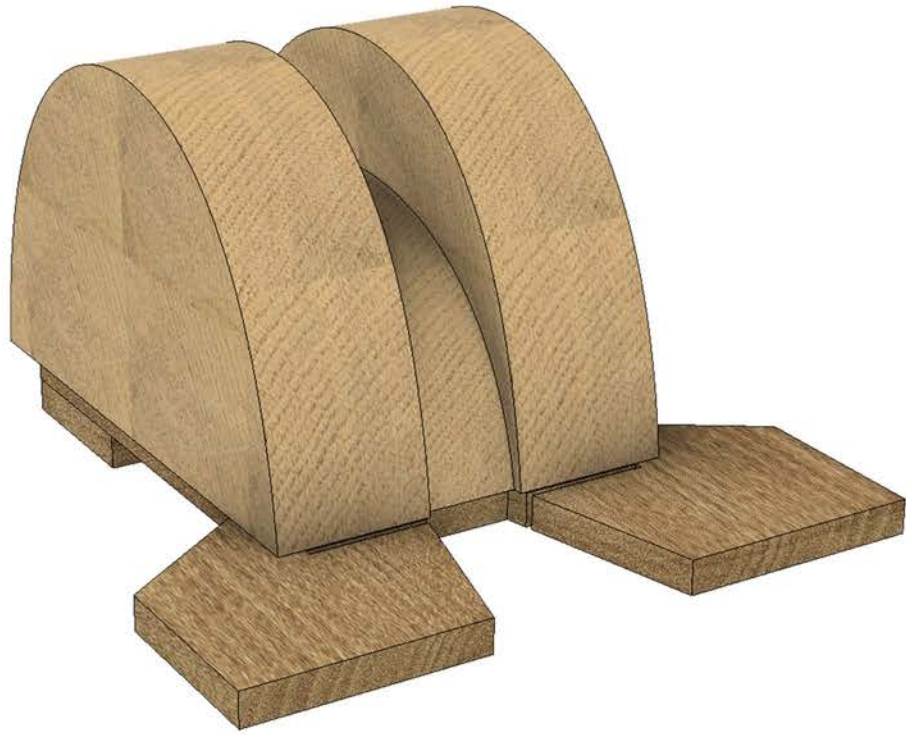

**TOP VIEW**

**USING A SAW BLADE CUT SLOTS INTO THE BASE PLATE TO ALLOW THE SUPPORT STRAP TO FEED THROUGH, MAKE THESE CUTS 3MM LONGER THAN THE WIDTH OF YOUR STRAP**

# THANK YOU!

---

Thank you so much if you have downloaded this project to help bring much needed PPE (Personal Protective Equipment) to the many front-line workers out there risking their lives without the adequate protection that they need.

PLEASE NOTE: These visors currently have not been passed for use in the NHS or other Medical healthcare organisations, so anyone who uses these masks must understand that with any piece of protective equipment it may not protect you fully 100% so you must understand the risks when using the product.

If you can help in any other way, for example providing pre-cut plastic sheets or providing the material to make the wooden forms, please let me know as it is becoming difficult to source materials as lots of businesses are now closed and there are long delivery times for goods bought on-line.

If you have any suggestions for what could be used for the elastic straps or if there is an 'off the shelf' head band design that could be used instead of making the elastic straps by hand then please let me know.

If you know of any healthcare organisations involved in the fight against Coronavirus that are in desperate need for visors, please let me know so I can try and find out if I can help provide some or try and pass the message onto others who are helping to provide much needed visors.

Lastly I would love to hear your thoughts on this design and any feedback you have on how you have used this project to provide valuable PPE to those who desperately need it, or for any improvements on how this design can be made better or if you have some ideas on anything else that I could help design or for anything else, please get in touch.

More information and a detailed video can be found here on my website:

<https://www.1sttrackdents.co.uk/coronavirus>

All the best and stay safe!

Jake Quintin

[info@1sttrackdents.co.uk](mailto:info@1sttrackdents.co.uk)